

Idea bank – Chain conveyor

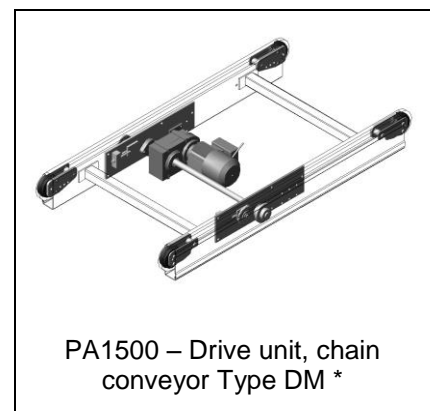

* Datasheet available

Idea bank – Chain conveyor

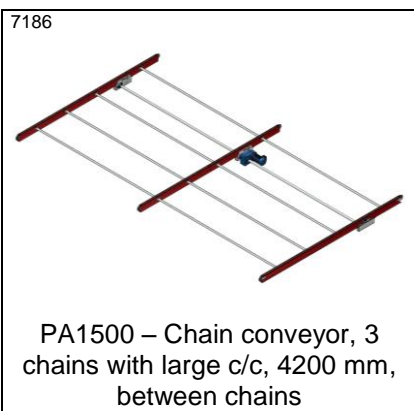
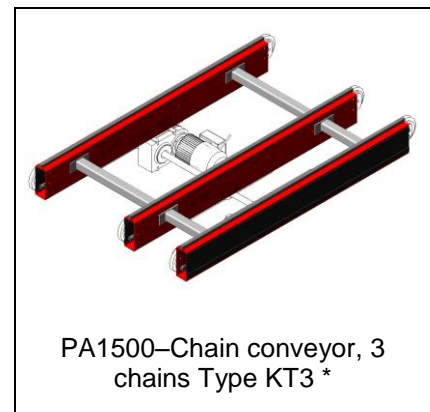
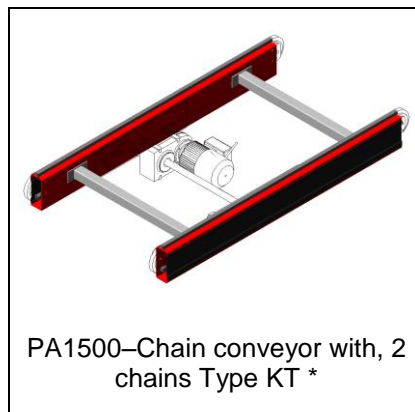
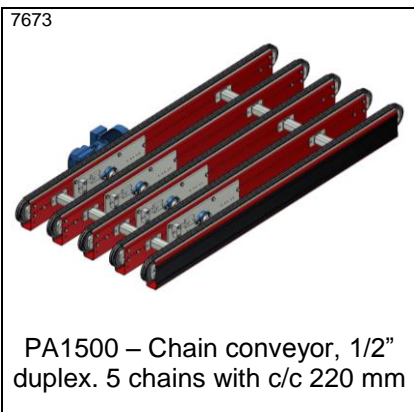
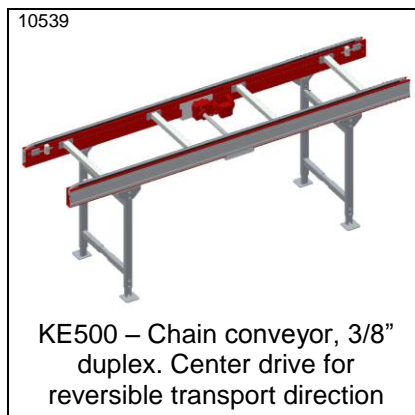
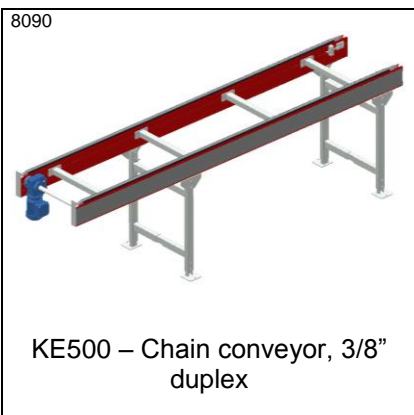
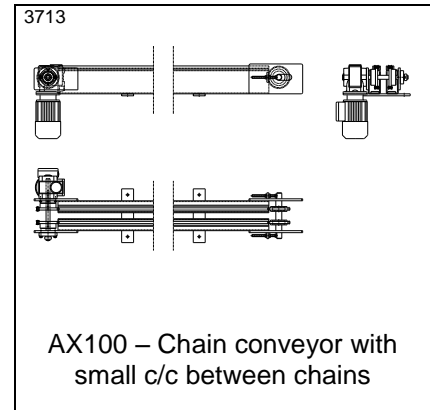
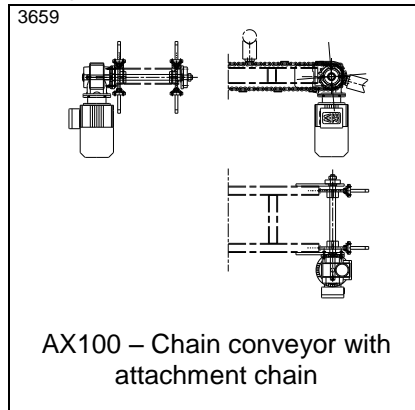
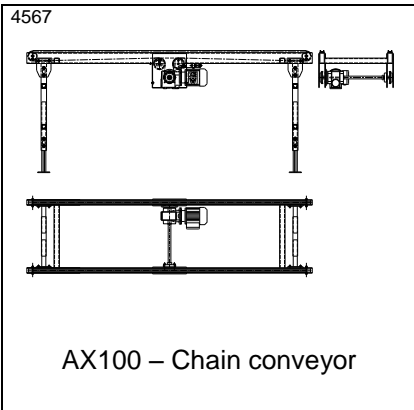
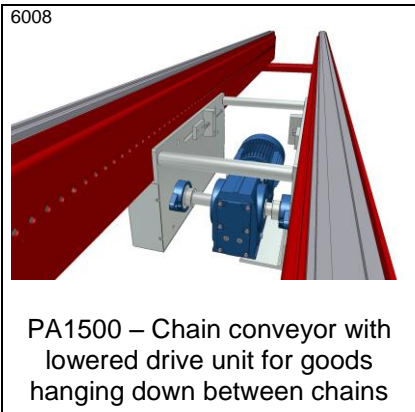

PA1500 – Chain conveyor with lowered drive unit for goods hanging down between chains

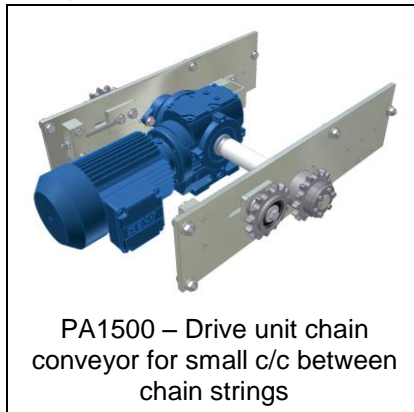

PA1500 – Drive unit chain conveyor for small c/c between chain strings

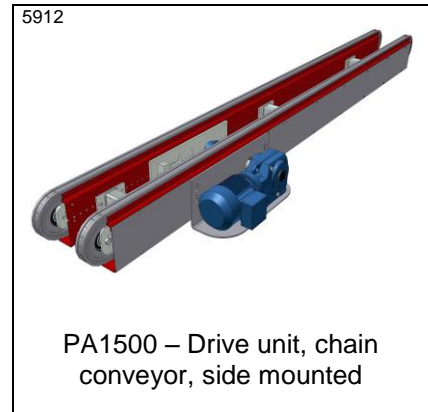

PA1500 – Drive unit, chain conveyor, side mounted

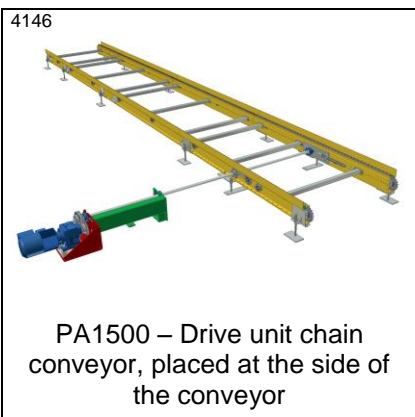

PA1500 – Drive unit chain conveyor, placed at the side of the conveyor

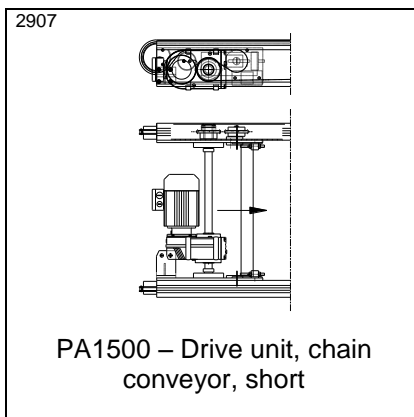

PA1500 – Drive unit, chain conveyor, short

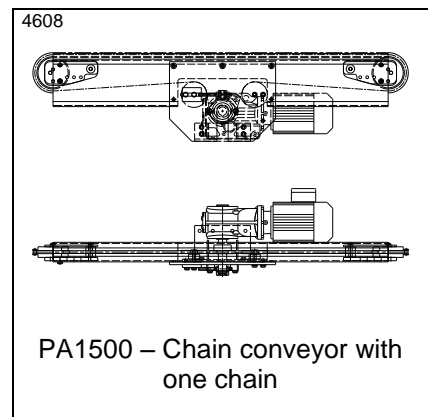

PA1500 – Chain conveyor with one chain

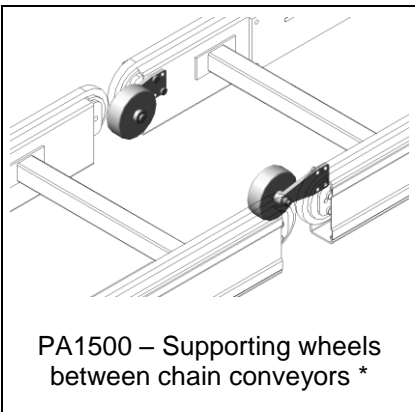

PA1500 – Supporting wheels between chain conveyors *

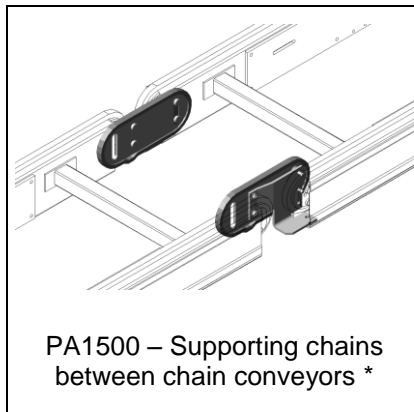

PA1500 – Supporting chains between chain conveyors *

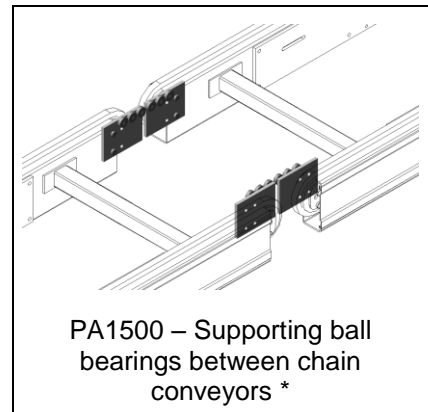

PA1500 – Supporting ball bearings between chain conveyors *

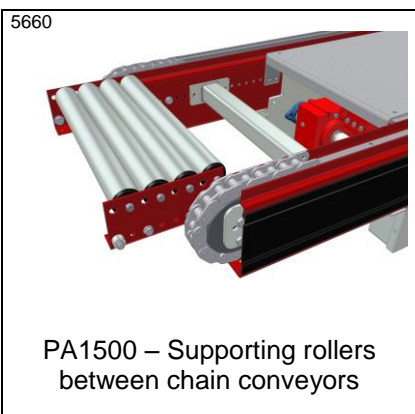

PA1500 – Supporting rollers between chain conveyors

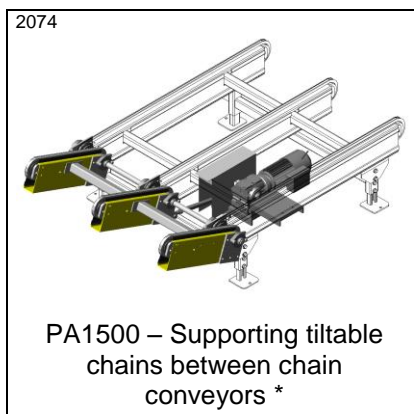

PA1500 – Supporting tiltable chains between chain conveyors *

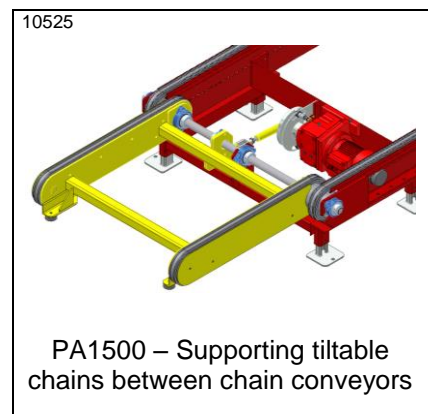

PA1500 – Supporting tiltable chains between chain conveyors

* Datasheet available

Idea bank – Chain conveyor

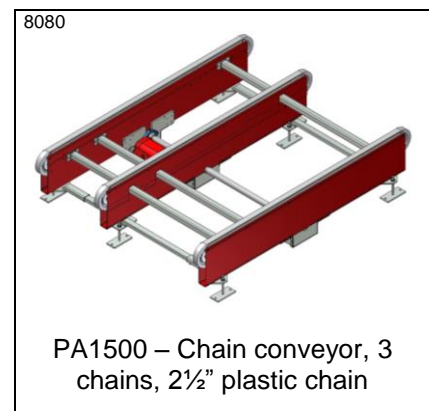
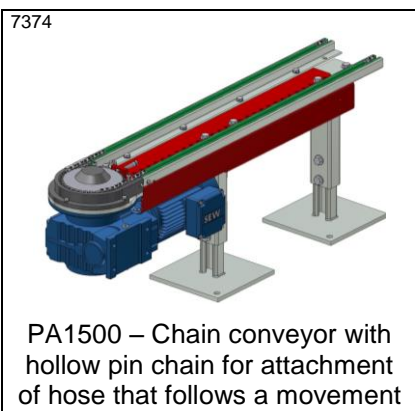
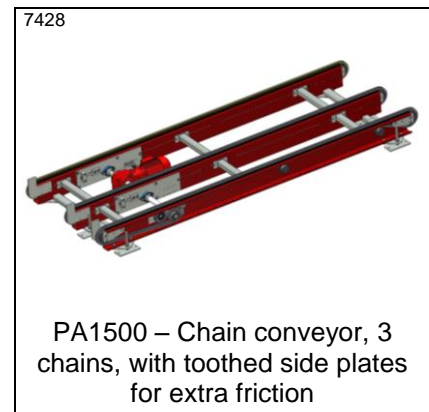
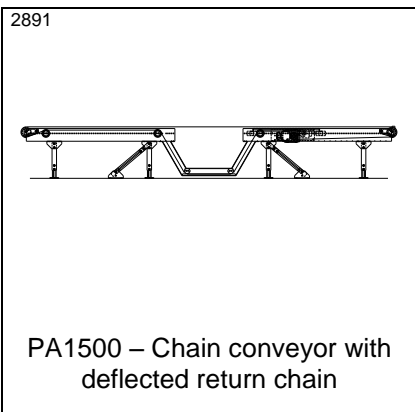
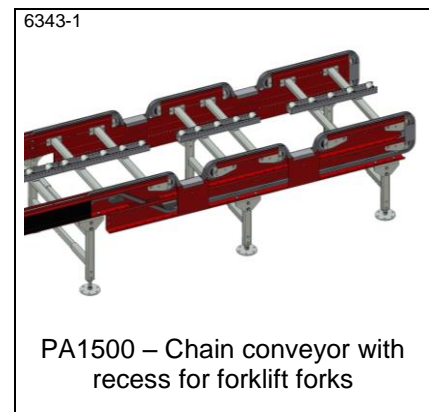
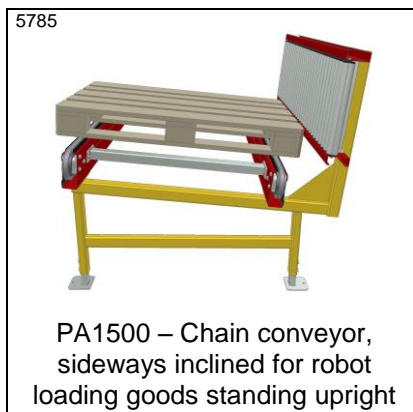
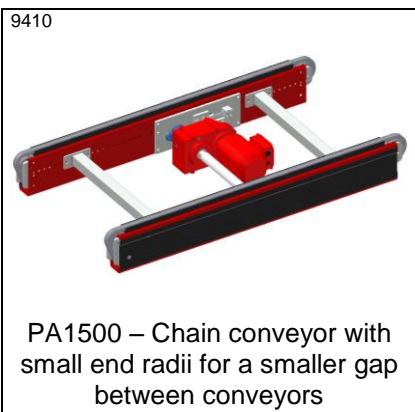
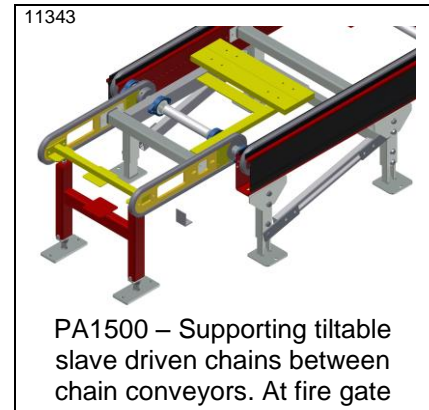
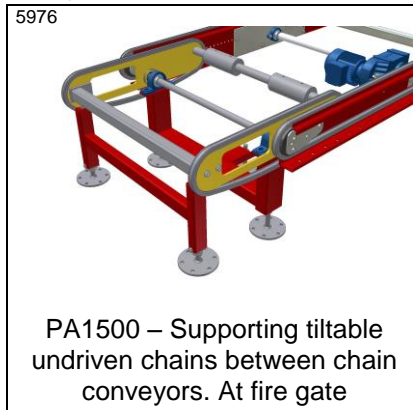
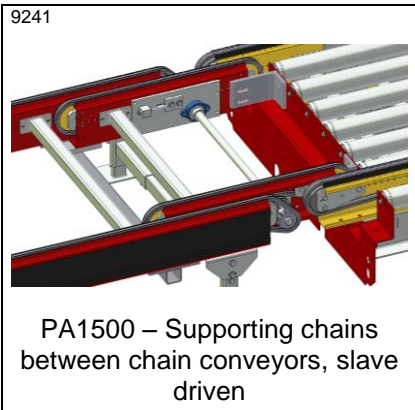

* Datasheet available