

## FR100 – Drive unit, underlying Type DU

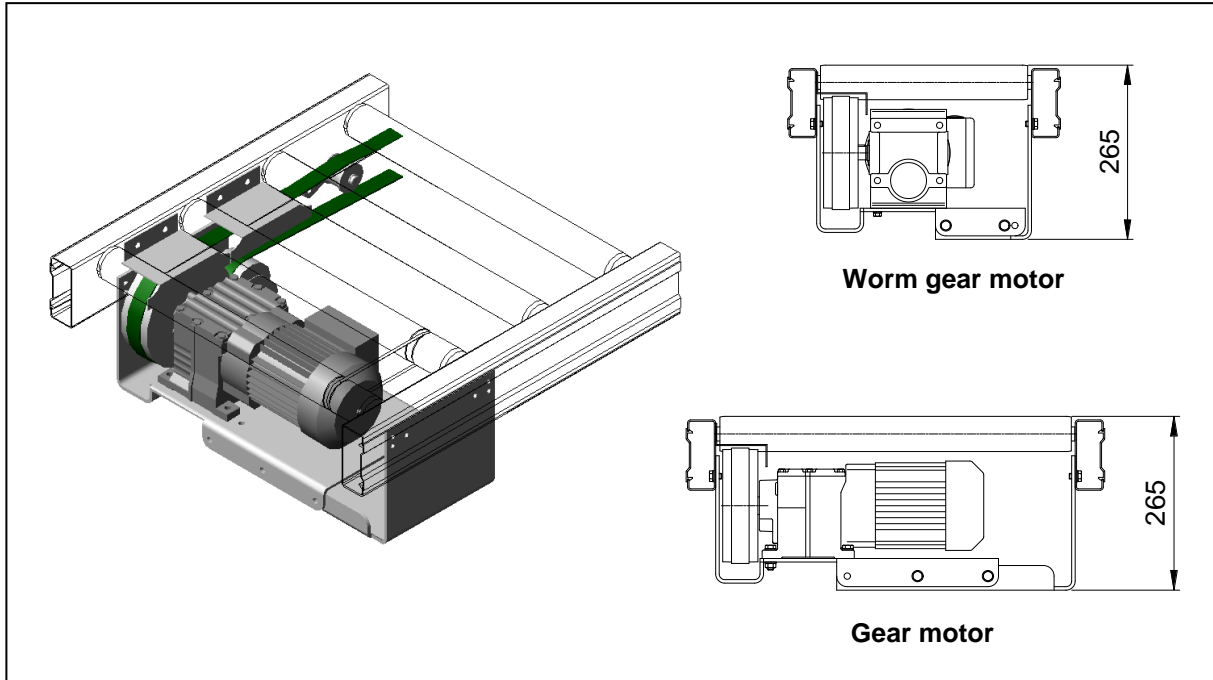

### Area of usage:

Drive unit for roller conveyor system FR100.

### Technical data:

Gear type:	Gear motor or worm gear motor, see table below.
Motor effect:	0.25, 0.37 and 0.55 kW, see table below.
Voltage:	230/400 V <sub>AC</sub> , 50 Hz.
Sealing class:	IP55.
Transport speed:	9, 12, 15, 20 and 30 m/min, see table below.
For roller length:	300, 400, 500, 600, 700, 800 and 900 mm.
Conveyor length:	Max 15 m per drive unit or max 100 rollers per drive unit.

### Surface treatment:

Zinc plated.

### Other:

Other motor effects and transport speeds on request.

Motor effect	0.25 kW		0.37 kW		0.55 kW	
	9 – 30 m/min		9 – 30 m/min		9 – 12 m/min	15 – 30 m/min
Roller length 300 mm	Worm gear motor		Worm gear motor		Doesn't exist	Worm gear motor
Roller length 400 mm	Gear motor		Worm gear motor		Doesn't exist	Worm gear motor
Roller length ≥ 500 mm	Gear motor		Gear motor		Doesn't exist	Gear motor