

Idea bank - Timing and V-beltconveyors

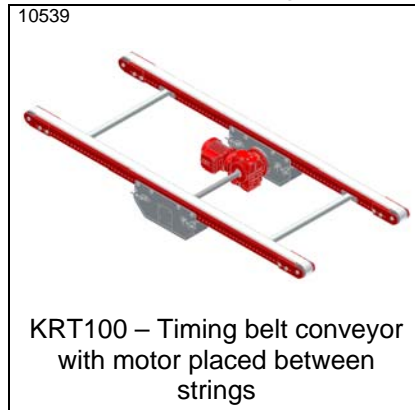

KRT100 – Timing belt conveyor



KRT100 – Timing belt conveyor with motor placed between strings



KRT100 – Timing belt conveyor with end mounted motor

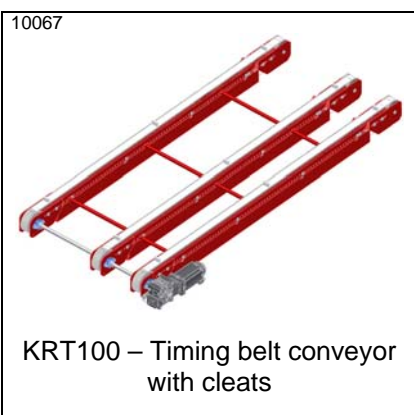

KRT100 – Timing belt conveyor with cleats

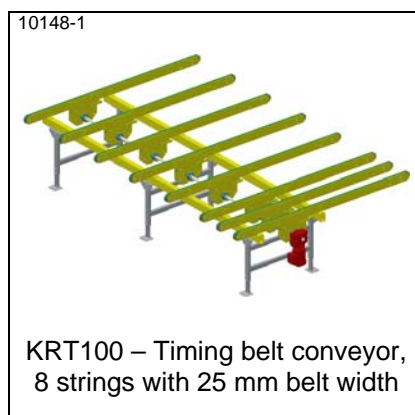

KRT100 – Timing belt conveyor, 8 strings with 25 mm belt width

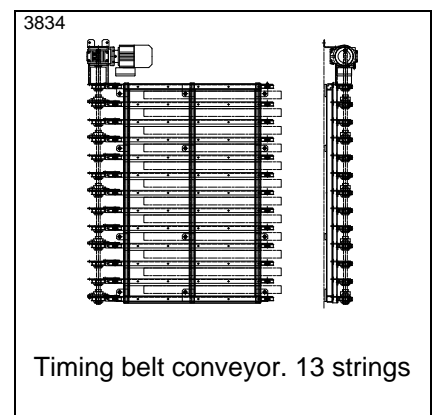

Timing belt conveyor. 13 strings

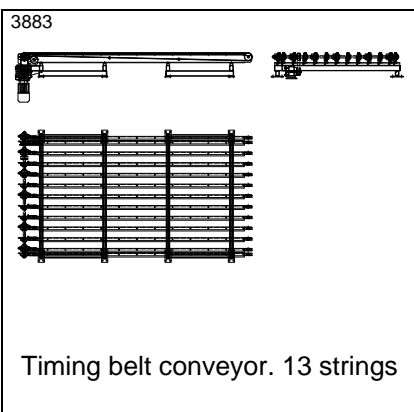

Timing belt conveyor. 13 strings

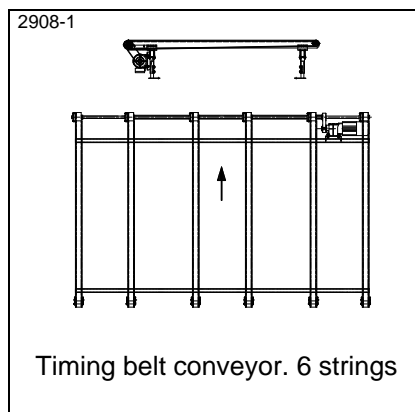

Timing belt conveyor. 6 strings

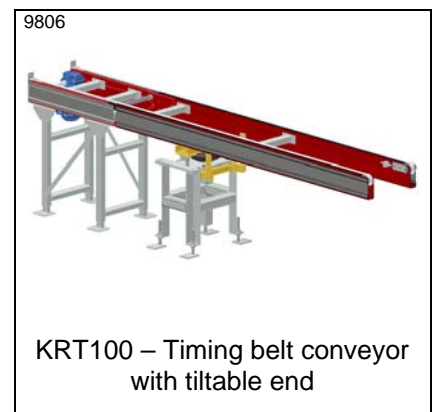

KRT100 – Timing belt conveyor with tiltable end

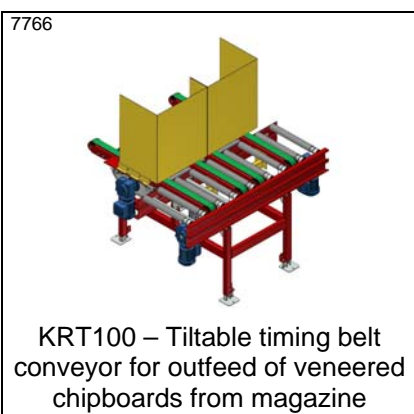

KRT100 – Tiltable timing belt conveyor for outfeed of veneered chipboards from magazine

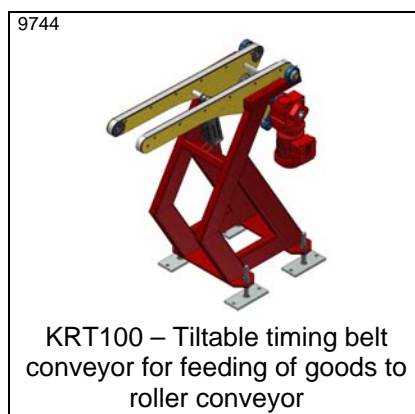

KRT100 – Tiltable timing belt conveyor for feeding of goods to roller conveyor

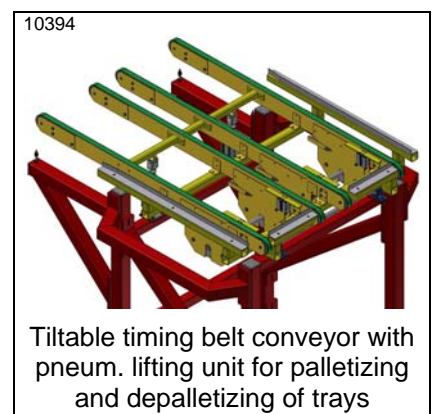

Tiltable timing belt conveyor with pneum. lifting unit for palletizing and depalletizing of trays

* Datasheet available

Material Handling Modules AB

Österlenvägen 280
S-270 21 Glemmingebro

Tel. + 46 411 55 89 80
Fax.+ 46 411 52 27 70

info@mhmodules.com
www.mhmodules.com

VAT: SE556490745801

Idea bank - Timing and V-beltconveyors

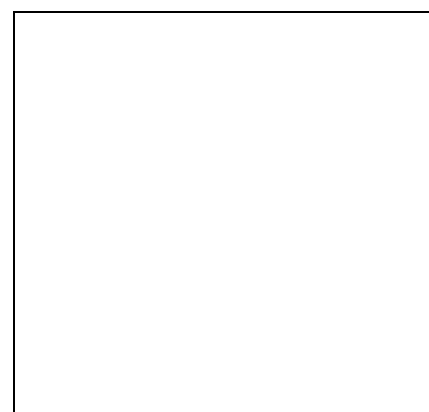
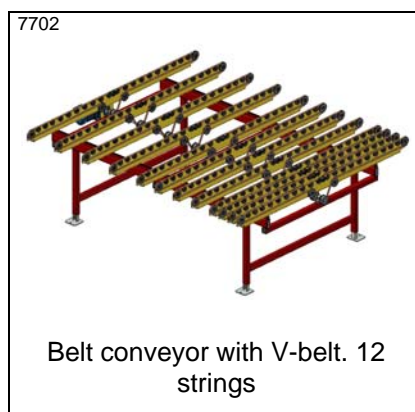
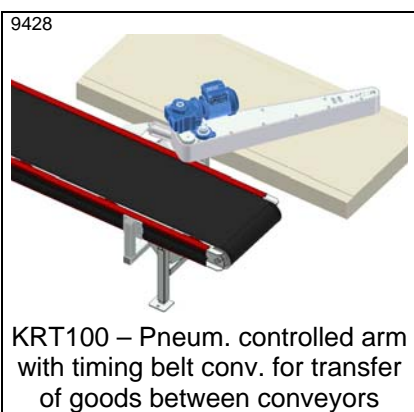
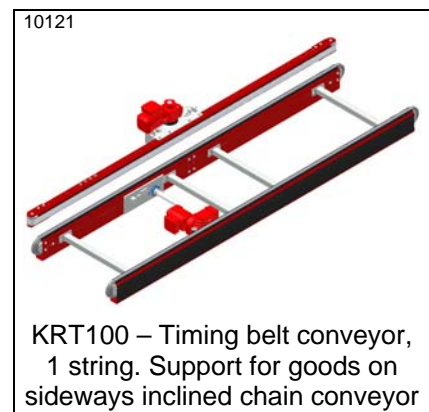
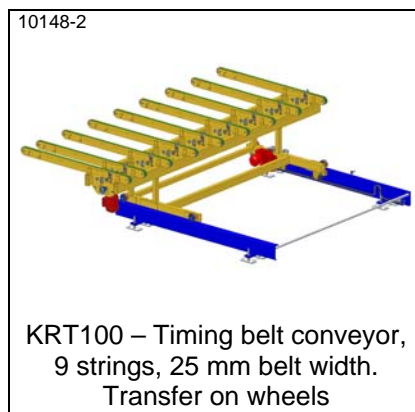
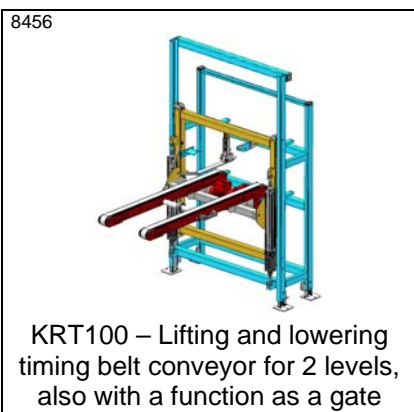
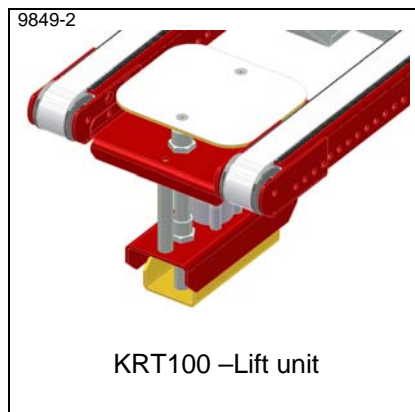
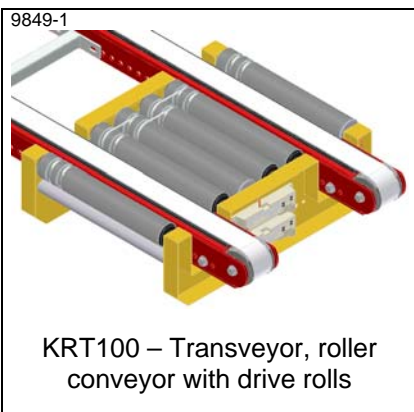
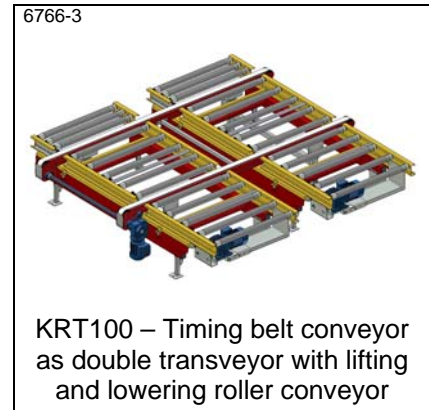
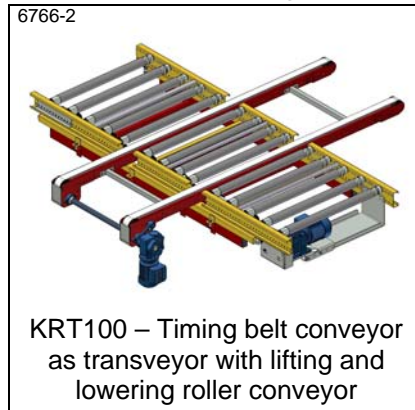
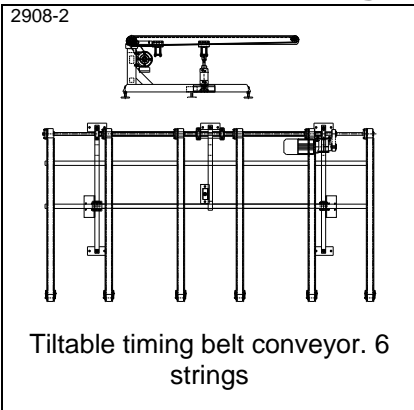

* Datasheet available