

## Idea bank – Drive units roller conveyors

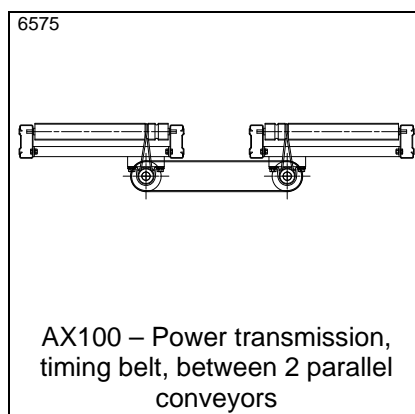

\* Datasheet available

## Idea bank – Drive units roller conveyors

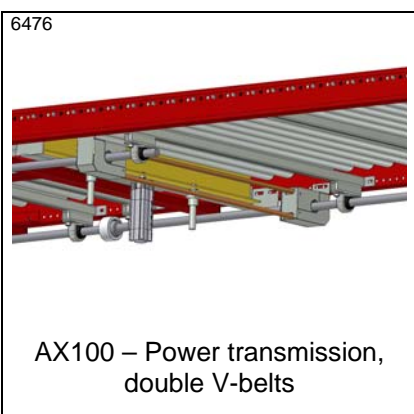
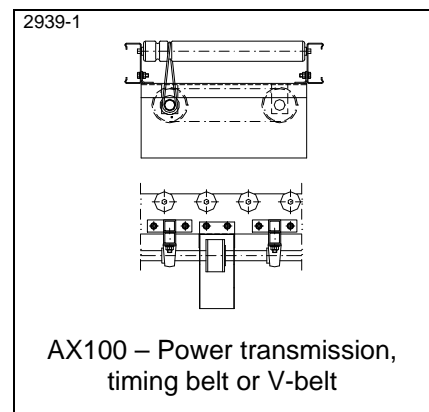
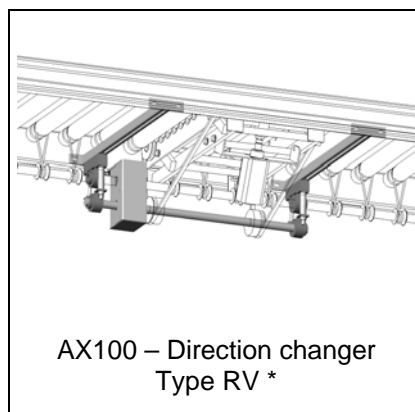
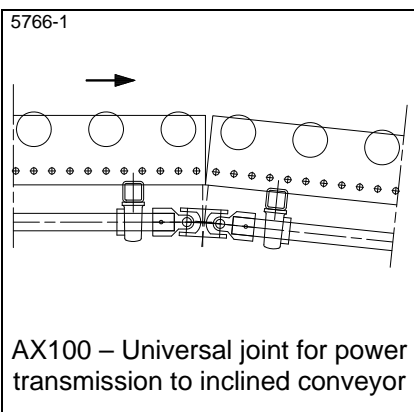
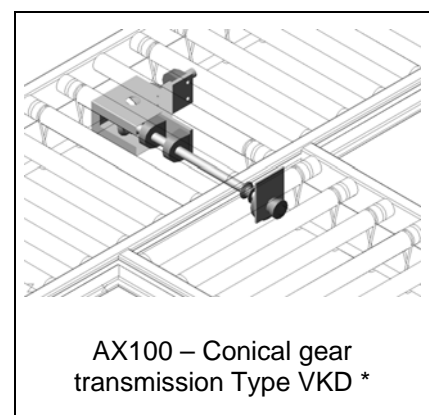
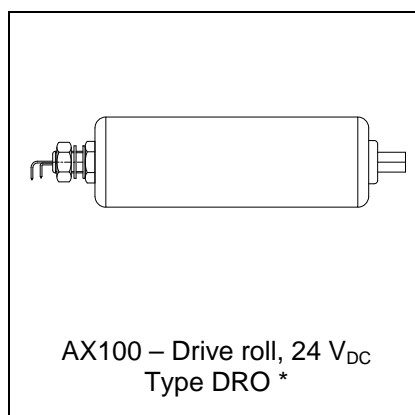
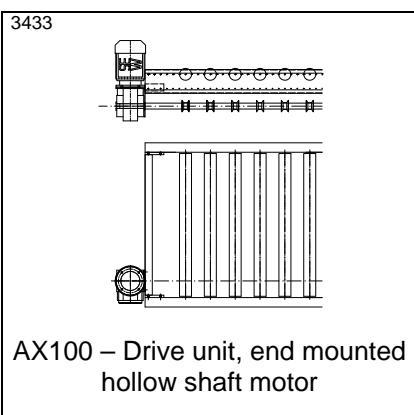
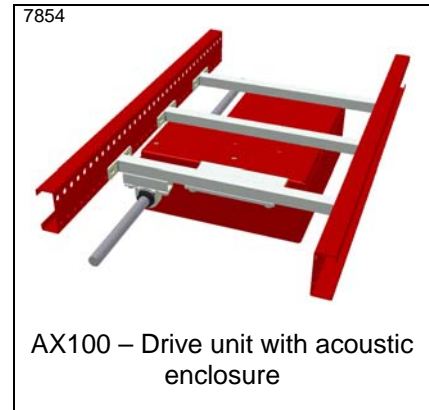
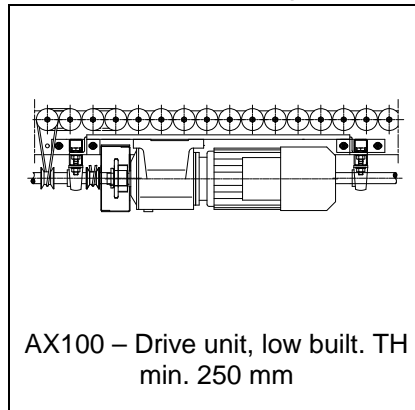
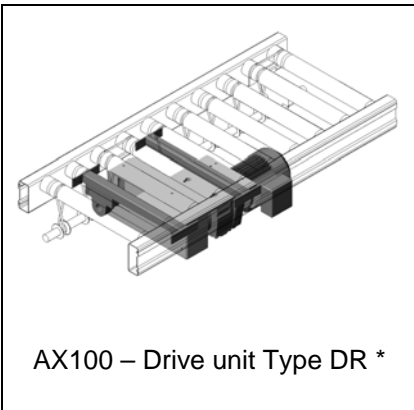
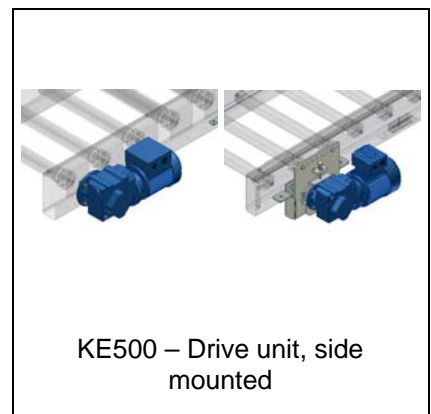
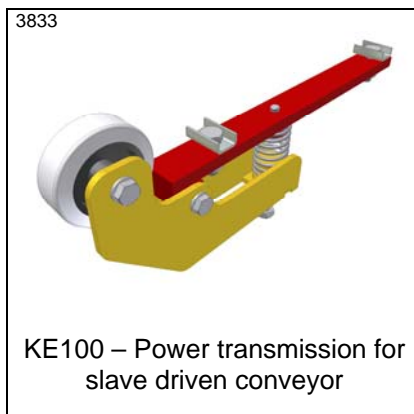
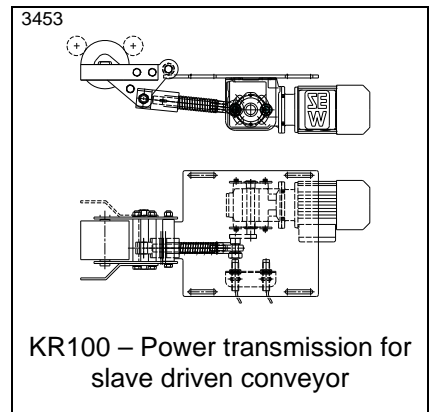
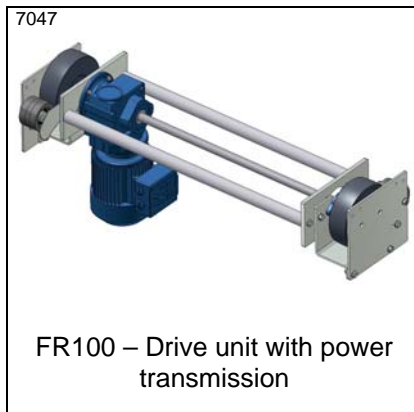
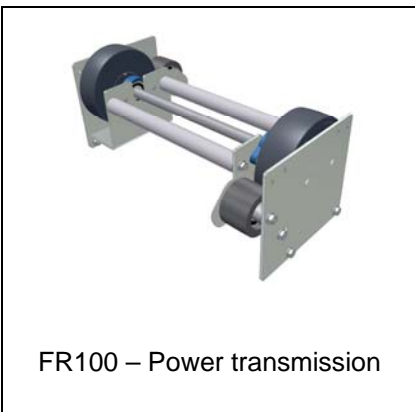
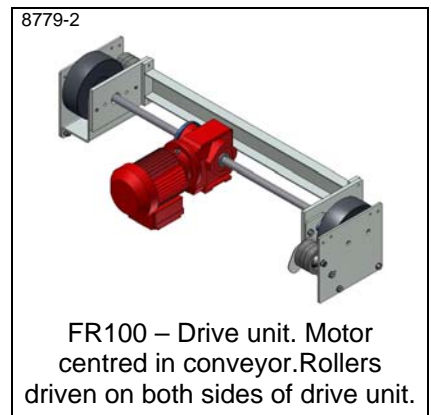
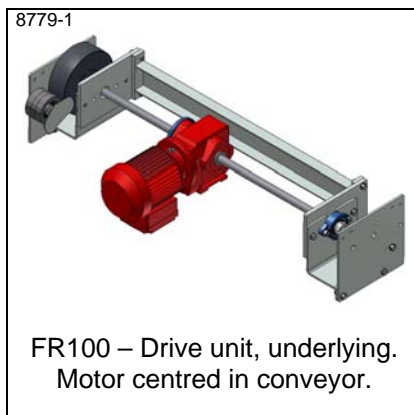
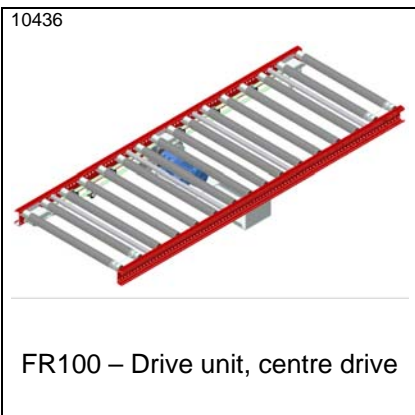
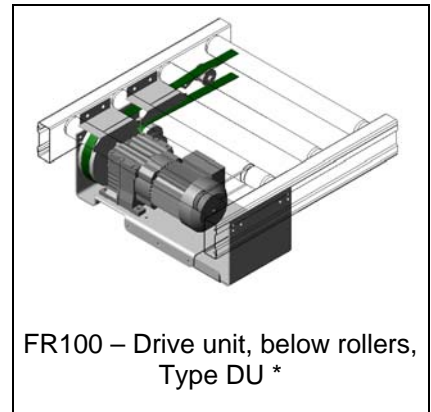
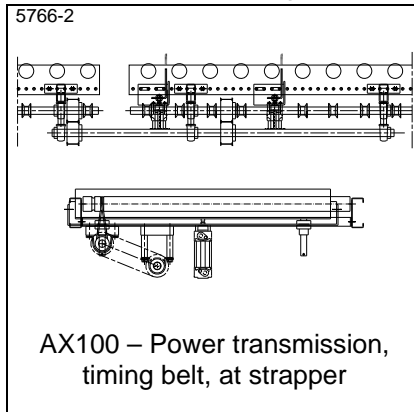
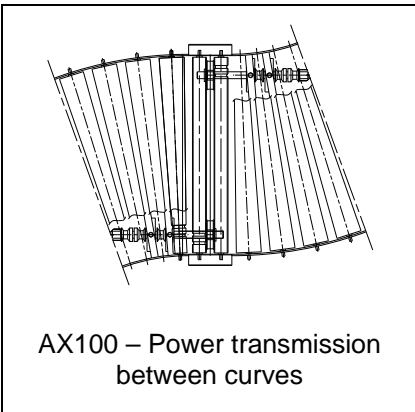

\* Datasheet available

## Idea bank – Drive units roller conveyors

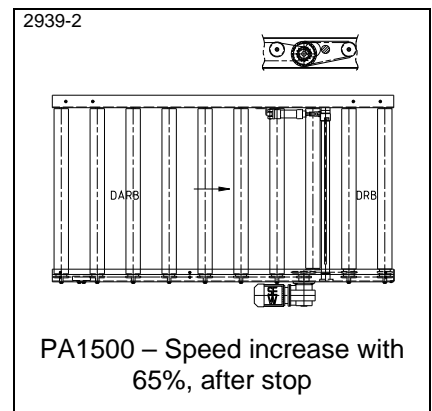
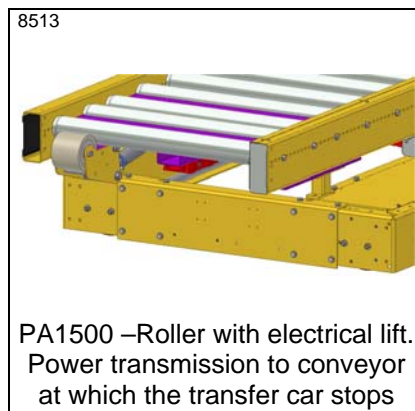
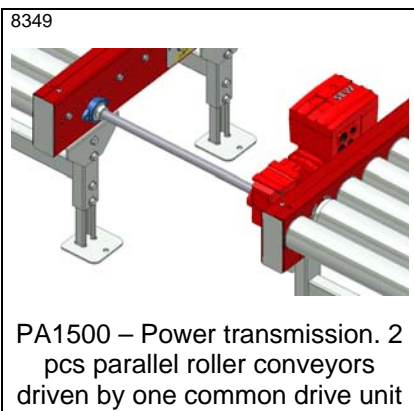
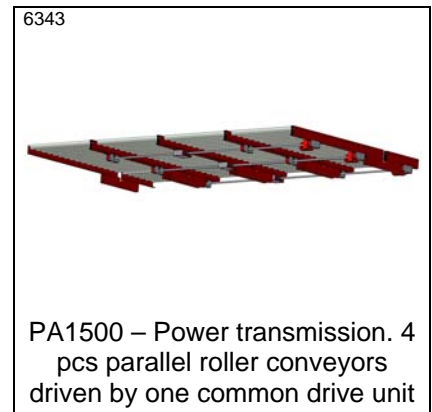
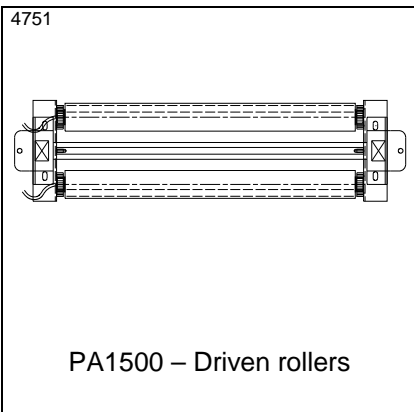
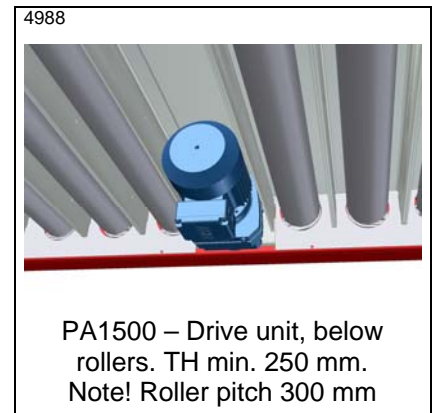
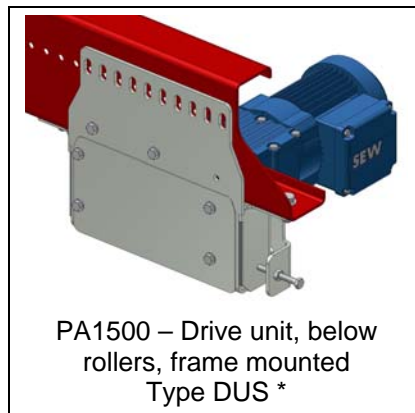
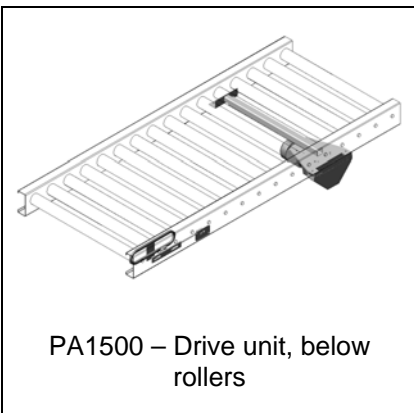
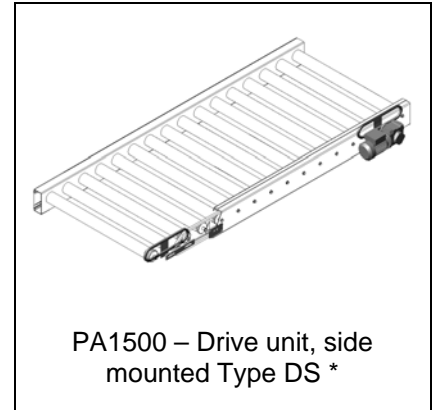
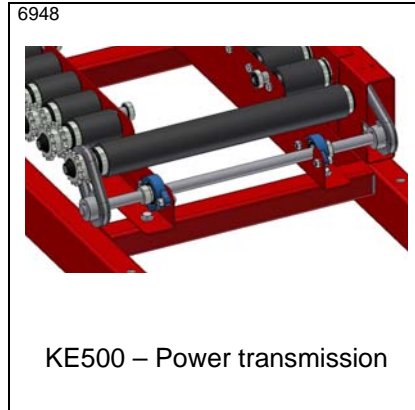

\* Datasheet available

### Material Handling Modules AB

Österlenvägen 280  
S-270 21 Glemmingebro

Tel. + 46 411 55 89 80  
Fax. + 46 411 52 27 70

info@mhmodules.com  
www.mhmodules.com

VAT: SE556490745801

## Idea bank – Drive units roller conveyors

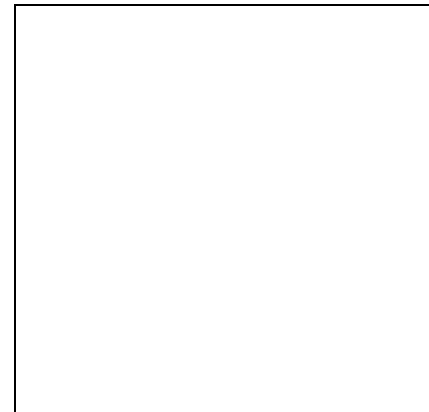
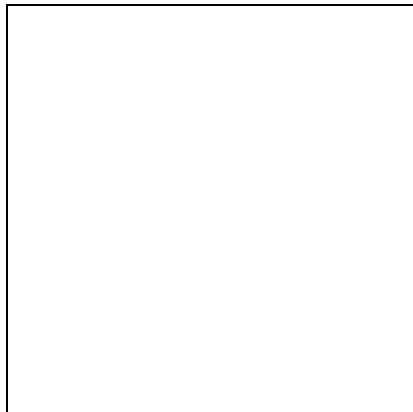
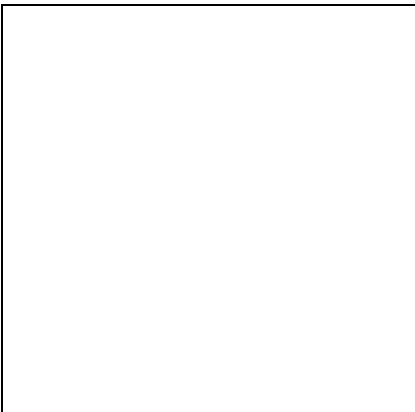
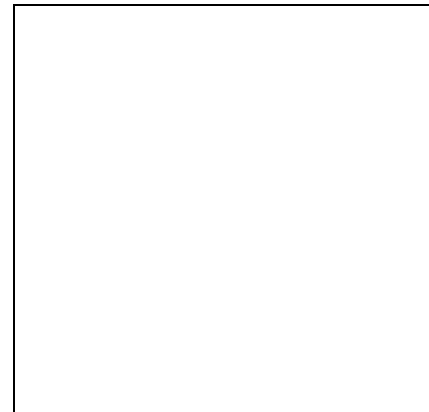
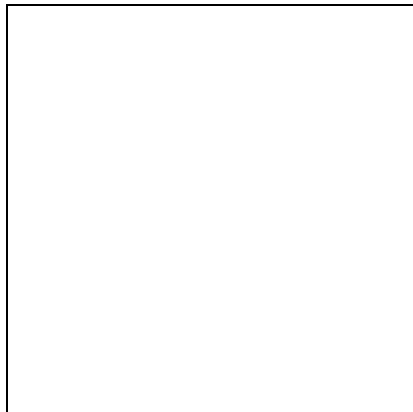
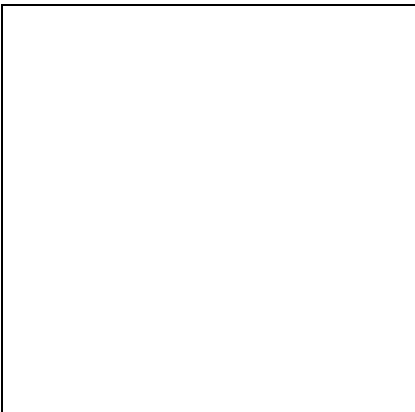
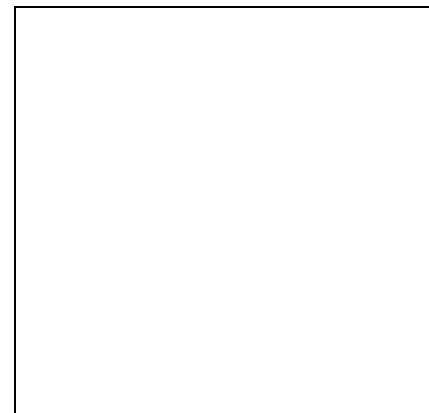
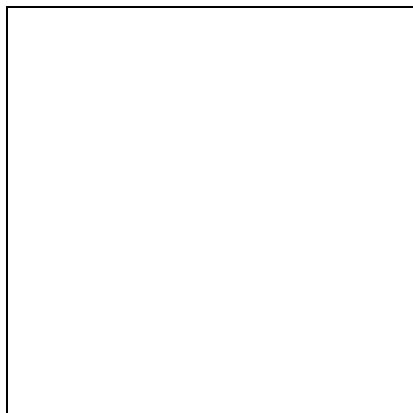
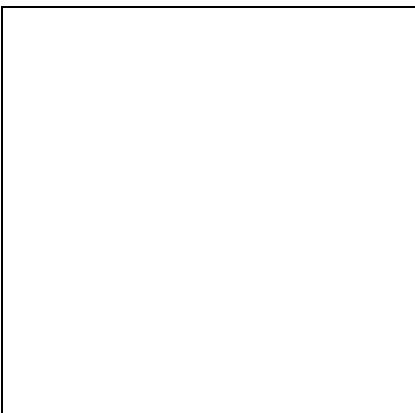
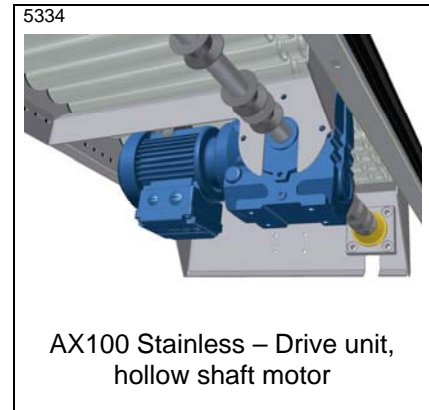
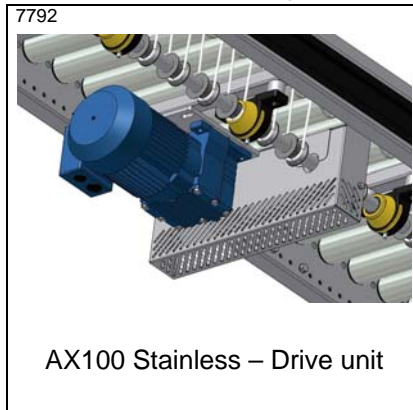
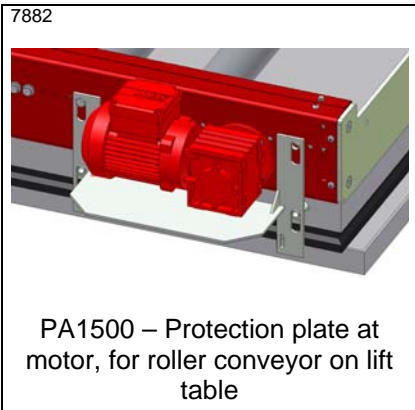

\* Datasheet available