

PA1500 – Stop, turn stop Type VS

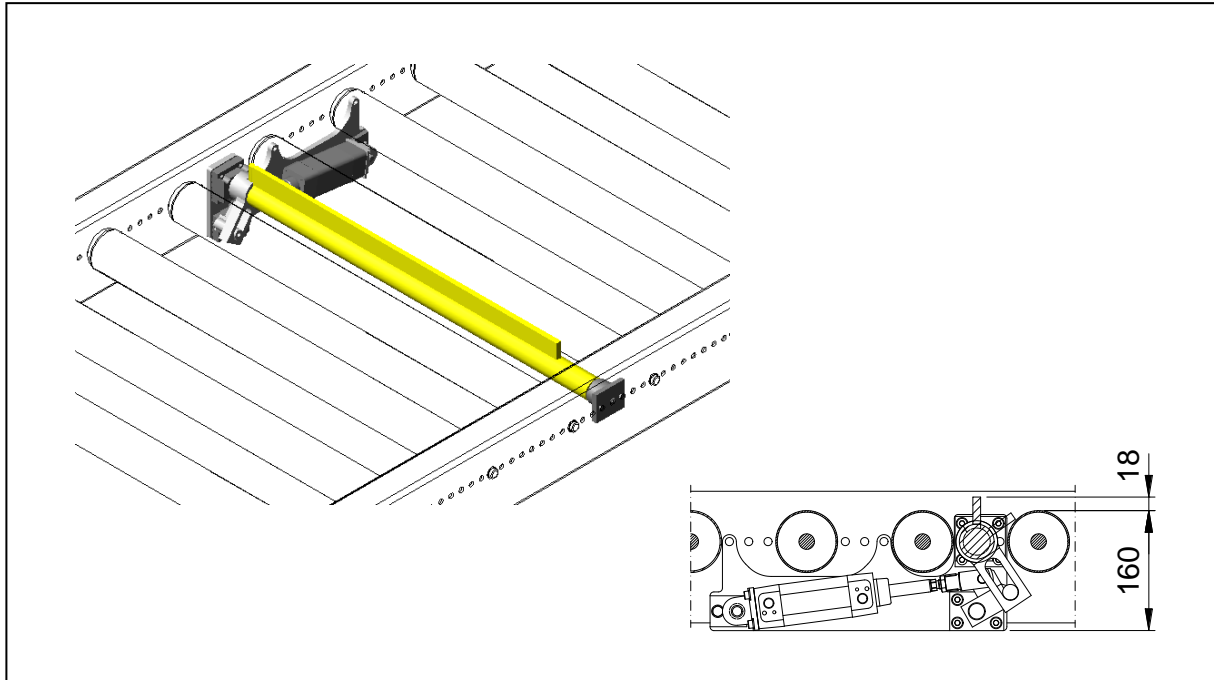

Area of usage:

To stop and separate pallets on accumulating roller conveyors. The rollers after the stop must be positive driven and have higher speed when separation is needed. May also be used as positioning stop in a positive driven roller conveyor. Should not be used when great accuracy on the goods position is needed, for example in a robot cell.

Technical data:

Self-locking knee-joint function.
Air consumption: 0.8 NL/cycle.
Cylinder: VDMA-standard.
Load: Max goods weight 6000 kg with a conveying speed of 9 m/min.
Applies to accumulating roller conveyors only.
For roller length: 900 and 1100 mm.

Surface treatment:

Stop plate: RAL1006 (yellow).
Other parts: Zinc plated.

Other:

Turn stop for gravity roller conveyor has as a standard the cylinder placed on the left side of the transport direction.
Delivered without pneumatic valve.
Other roller lengths on request.

PA1500 – Stop, turn stop Type VS

Article number:

Roller conveyors drive unit	Roller length	
	900 mm	1100 mm
Placed on right side	PAVSH0900001	PAVSH1100001
Placed on left side	PAVSV0900001	PAVSV1100001
Unpowered conveyor	PAVSO0900001	PAVSO1100001

Ensure the article number is stated when ordering.