

Idea bank – Pushers

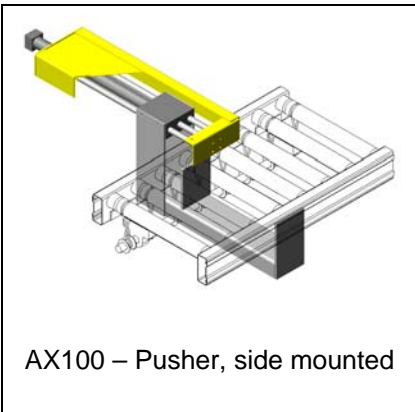

AX100 – Pusher, side mounted

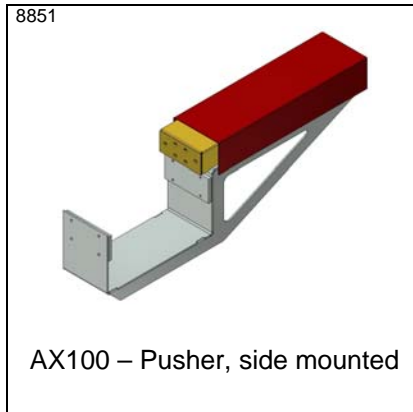

AX100 – Pusher, side mounted

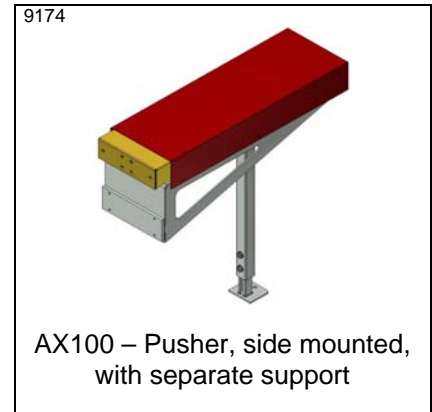

AX100 – Pusher, side mounted, with separate support

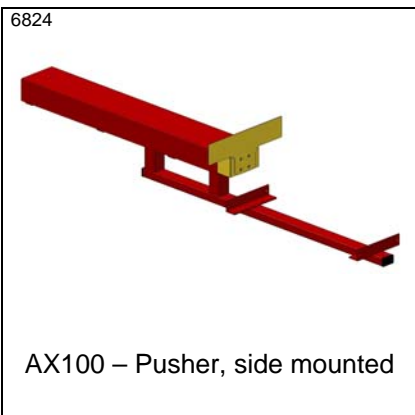

AX100 – Pusher, side mounted

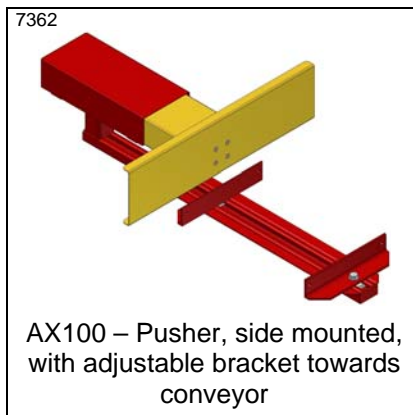

AX100 – Pusher, side mounted, with adjustable bracket towards conveyor

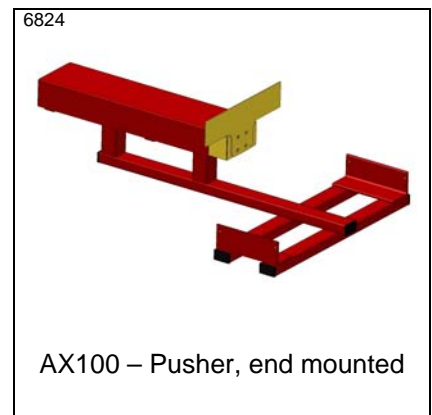

AX100 – Pusher, end mounted

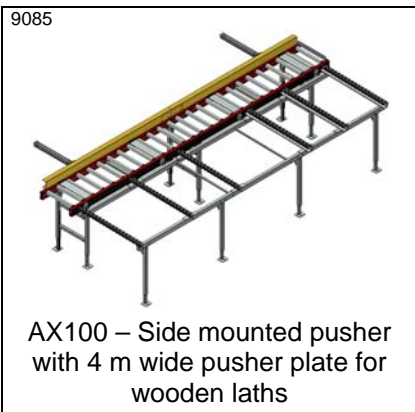

AX100 – Side mounted pusher with 4 m wide pusher plate for wooden laths

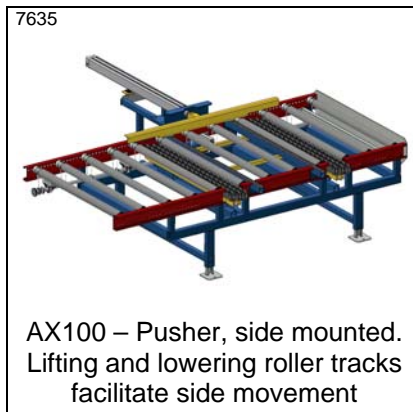

AX100 – Pusher, side mounted. Lifting and lowering roller tracks facilitate side movement

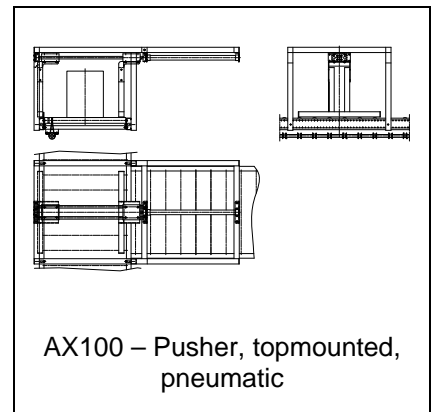

AX100 – Pusher, topmounted, pneumatic

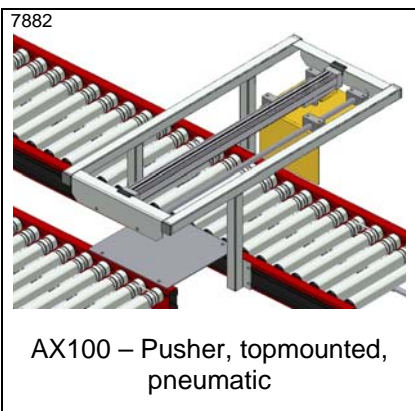

AX100 – Pusher, topmounted, pneumatic

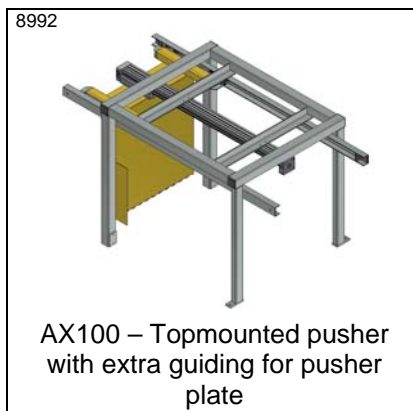

AX100 – Topmounted pusher with extra guiding for pusher plate

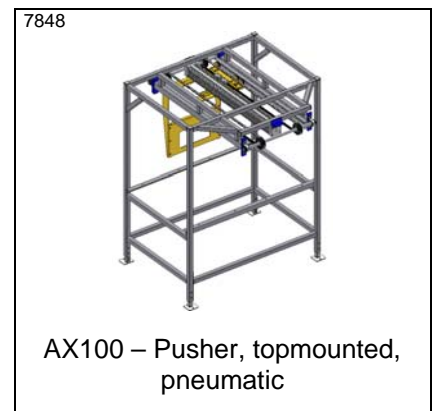

AX100 – Pusher, topmounted, pneumatic

* Datasheet available

Material Handling Modules AB

Österlenvägen 280
S-270 21 Glemmingebro

Tel. + 46 411 55 89 80
Fax. + 46 411 52 27 70

info@mhmodules.com
www.mhmodules.com

VAT: SE556490745801

Idea bank – Pushers

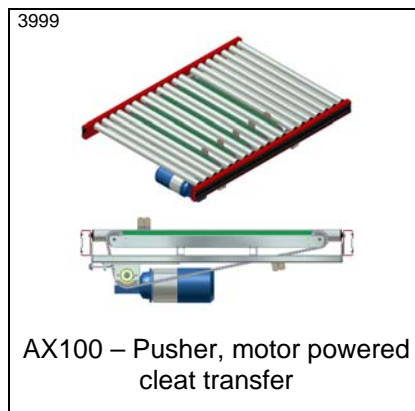
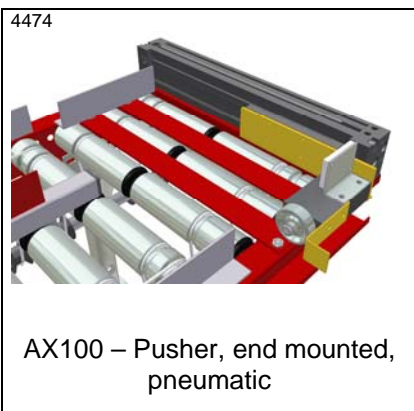
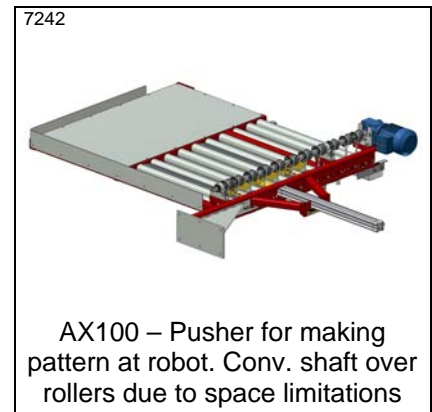
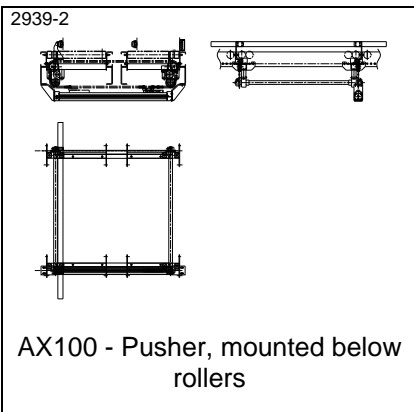
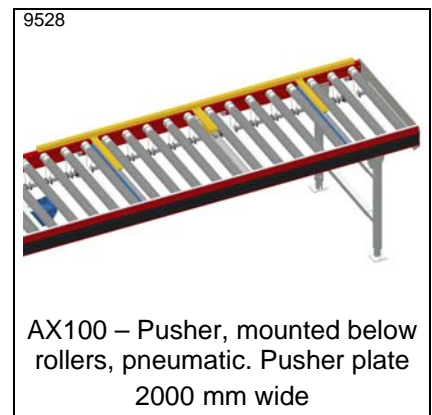
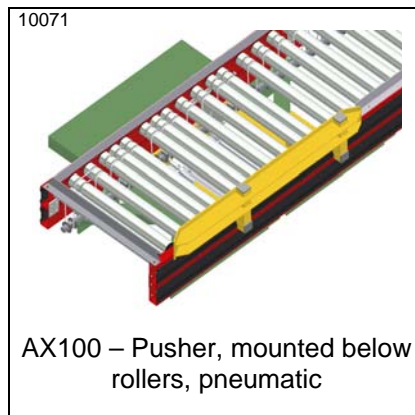
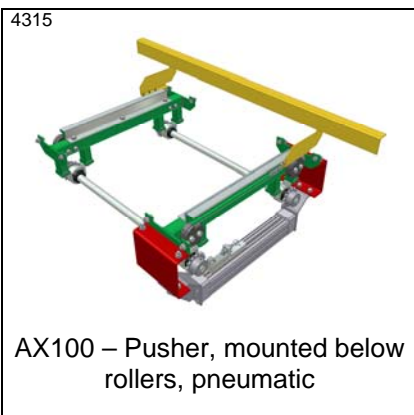
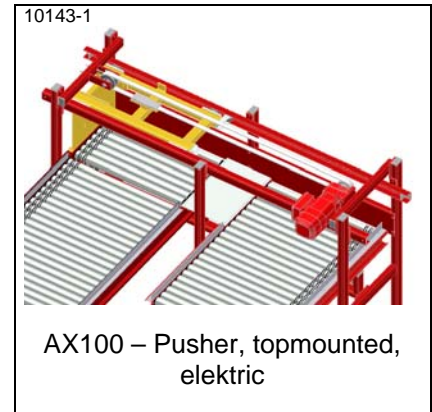
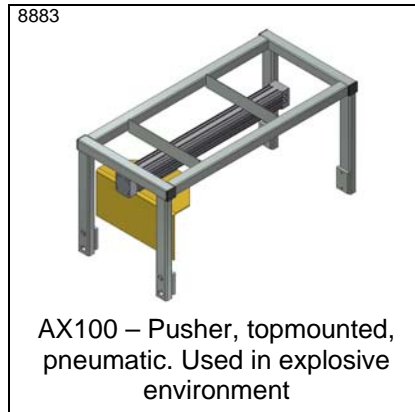
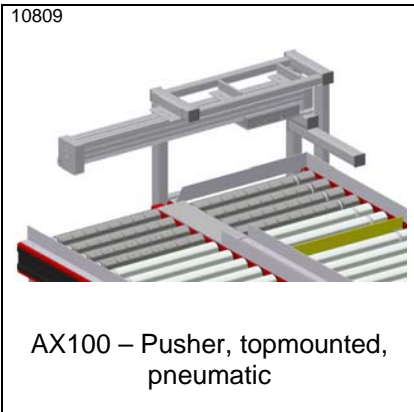

* Datasheet available

Idea bank – Pushers

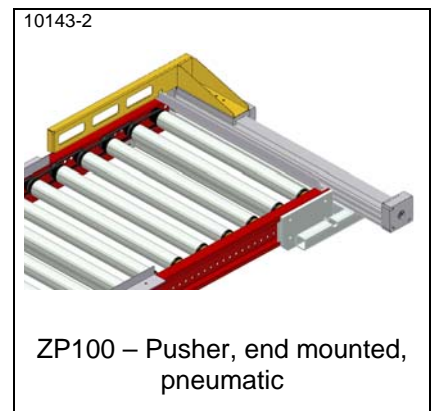
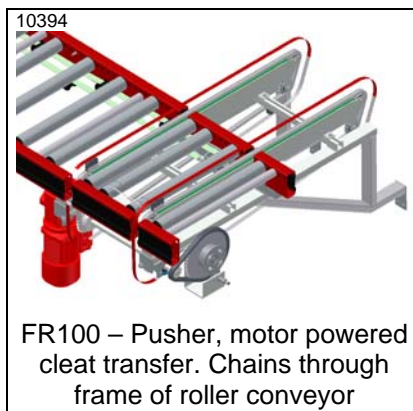
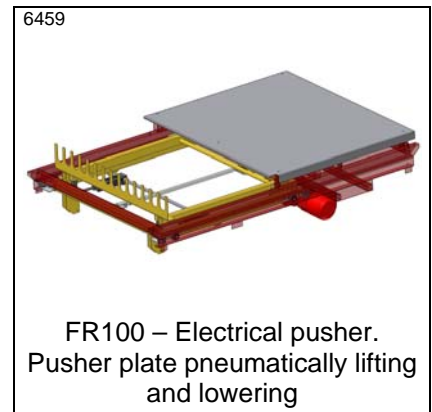
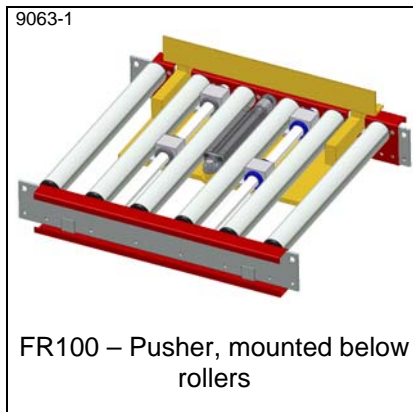
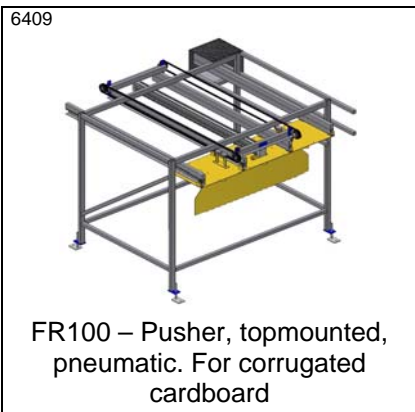
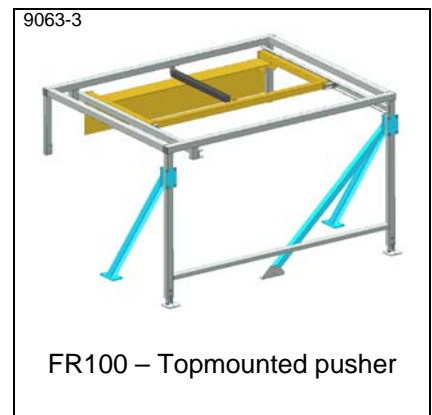
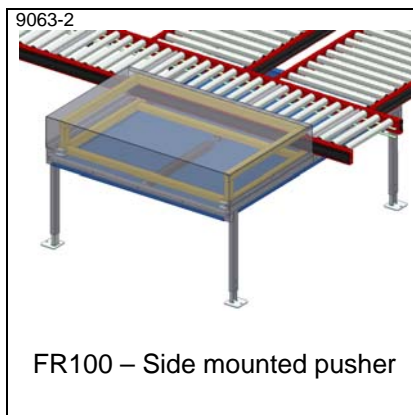
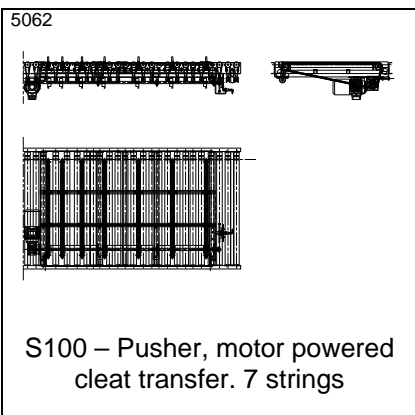
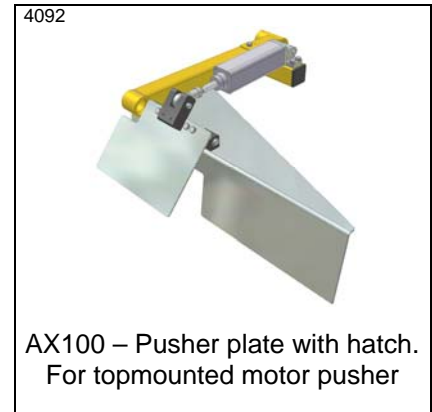
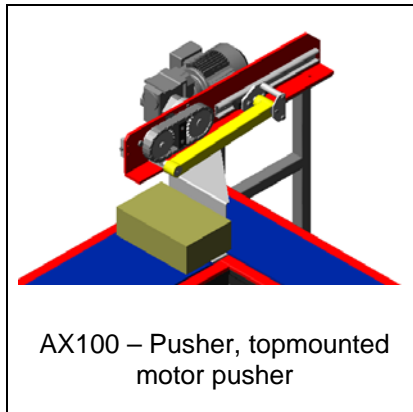
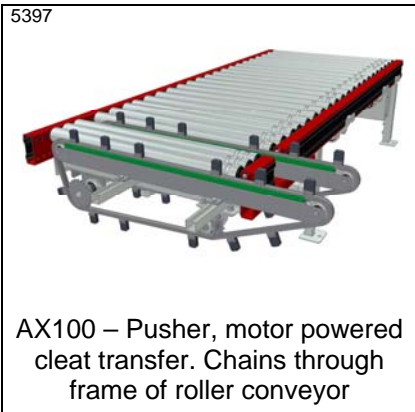

* Datasheet available

Idea bank – Pushers

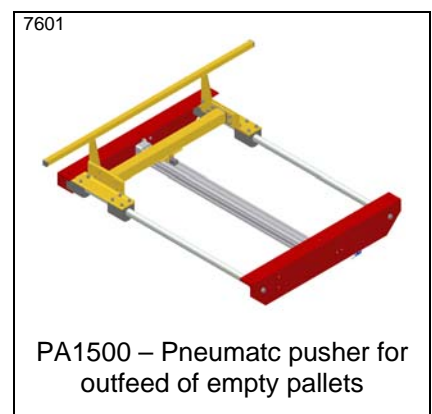
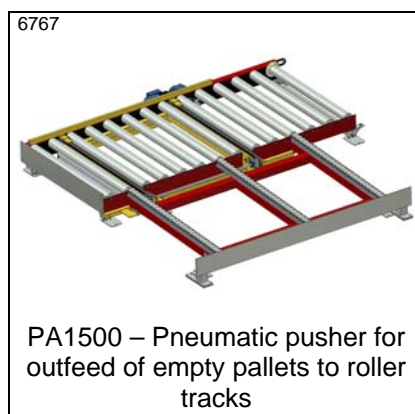
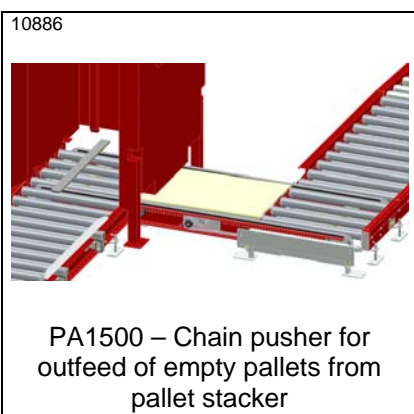
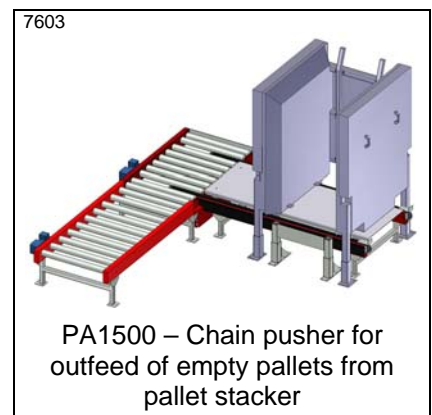
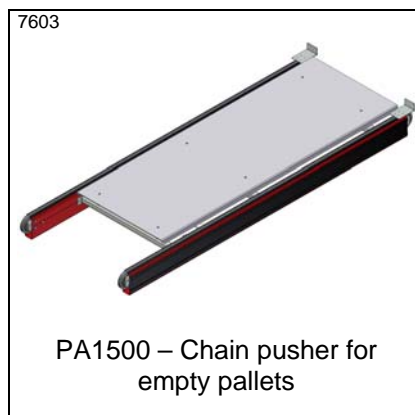
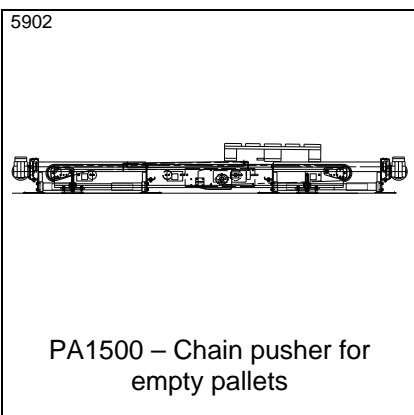
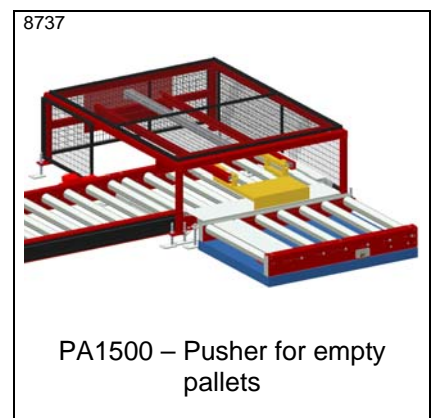
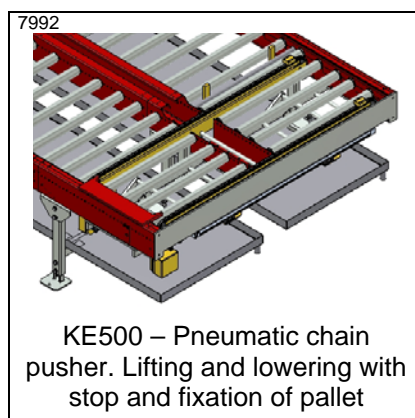
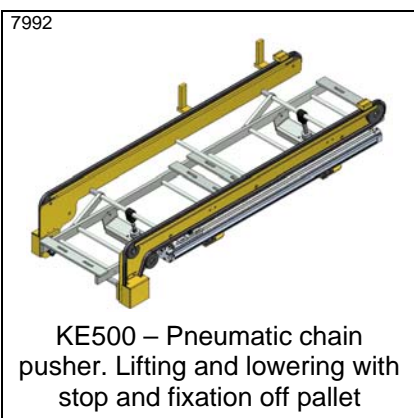
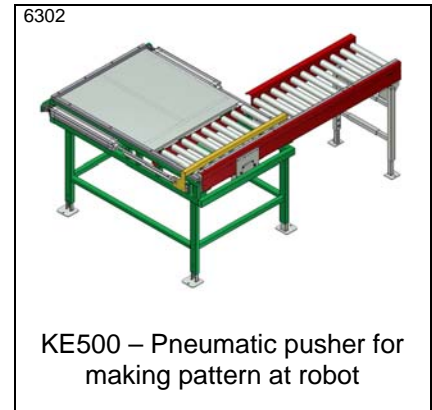
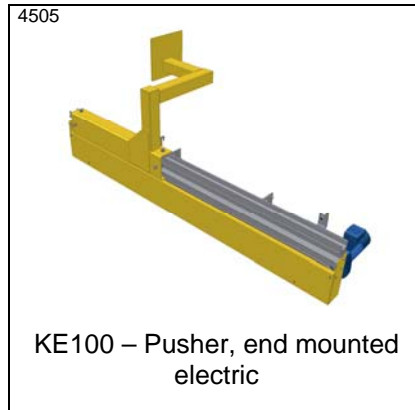
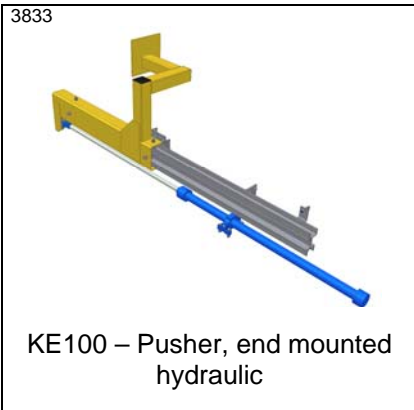

* Datasheet available

Idea bank – Pushers

7349



PA1500 – Pneumatic pusher with large c/c, 4050 mm, between pusher plates

6683

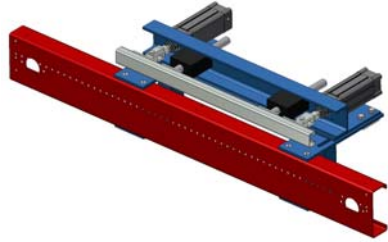

PL1500 – Pusher, side mounted

2939-3

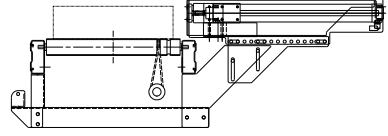

AX100 Stainless – Pusher, side mounted

2939-1

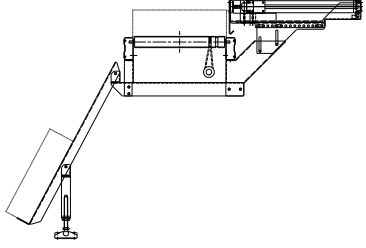

AX100 Stainless – Pusher, reject pusher

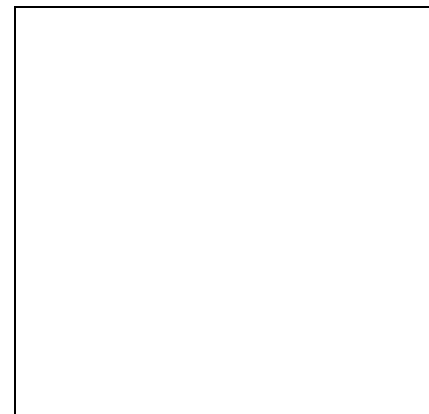
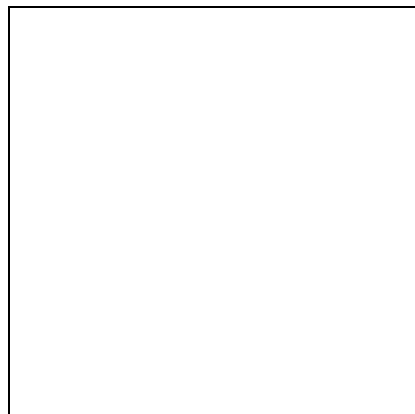
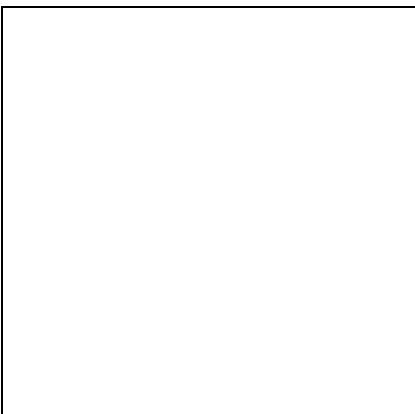
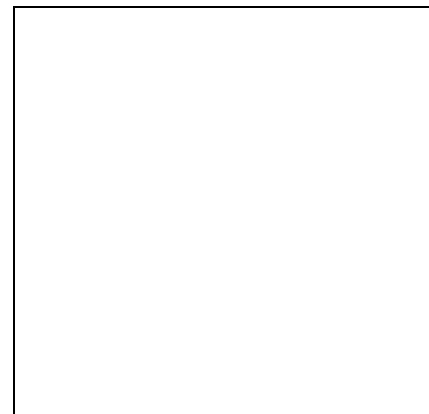
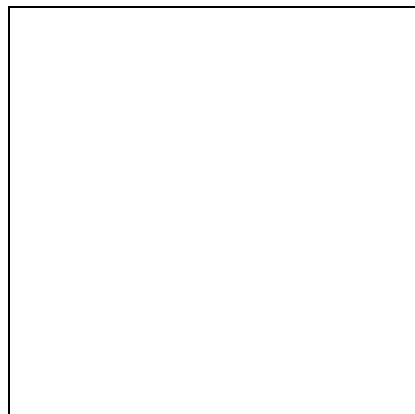
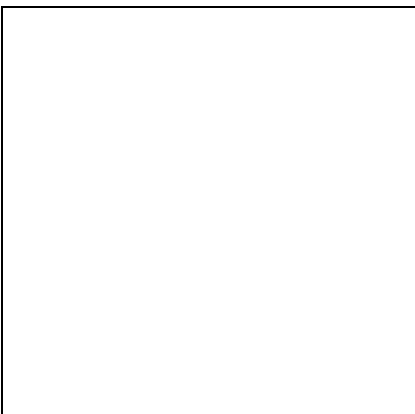
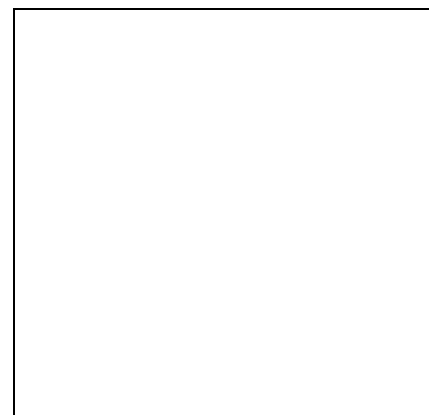
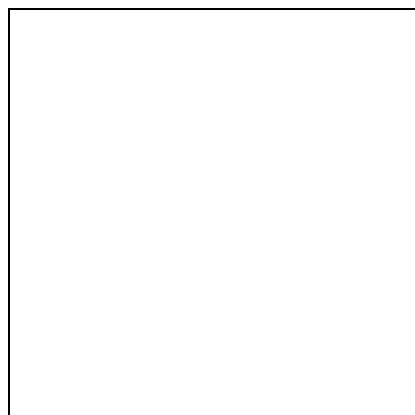

* Datasheet available