

KE 500 – Drive unit, Chain conveyor – Type DM

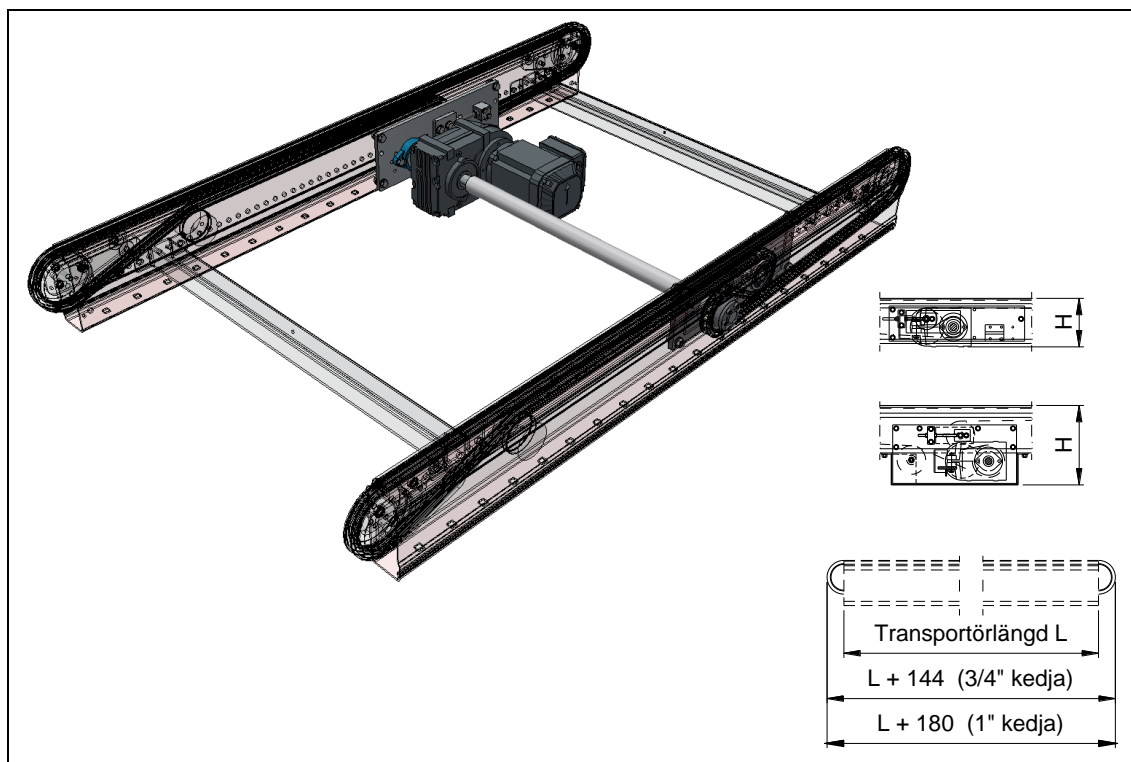

Field of application:

Drive unit for chain conveyor KE 500 type KT and KT3.

Technical data:

Gear type:	Cog gear motor.
Motor effect:	0,37, 0,55, 0,75 and 1,1 kW. For 1" chain, also 1.5 kW
Voltage:	230/400 V _{AC} , 50 Hz.
IP-code:	IP55
Speed:	6, 9 and 12 m/min.
C/c chains:	950 mm and 350/600 (3 chains) with 3/4"-chains also 950 mm with 1" chains.
Total length:	Max 10 800 mm per drive unit.
Height of drive unit:	See table below:

Motor effect (kW)	0,37			0,55			0,75			1,1			1,5		
	6	9	12	6	9	12	6	9	12	6	9	12	6	9	12
(H)eight with 3/4"-chains	215	215	215	215	215	215	225	215	215	240	225	225	-	-	-
(H)eight with 1"-chains	345	345	345	345	345	345	345	345	345	355	355	345	355	355	350