

KE 500 – Height-adjustable Chain conveyor – Type HSK

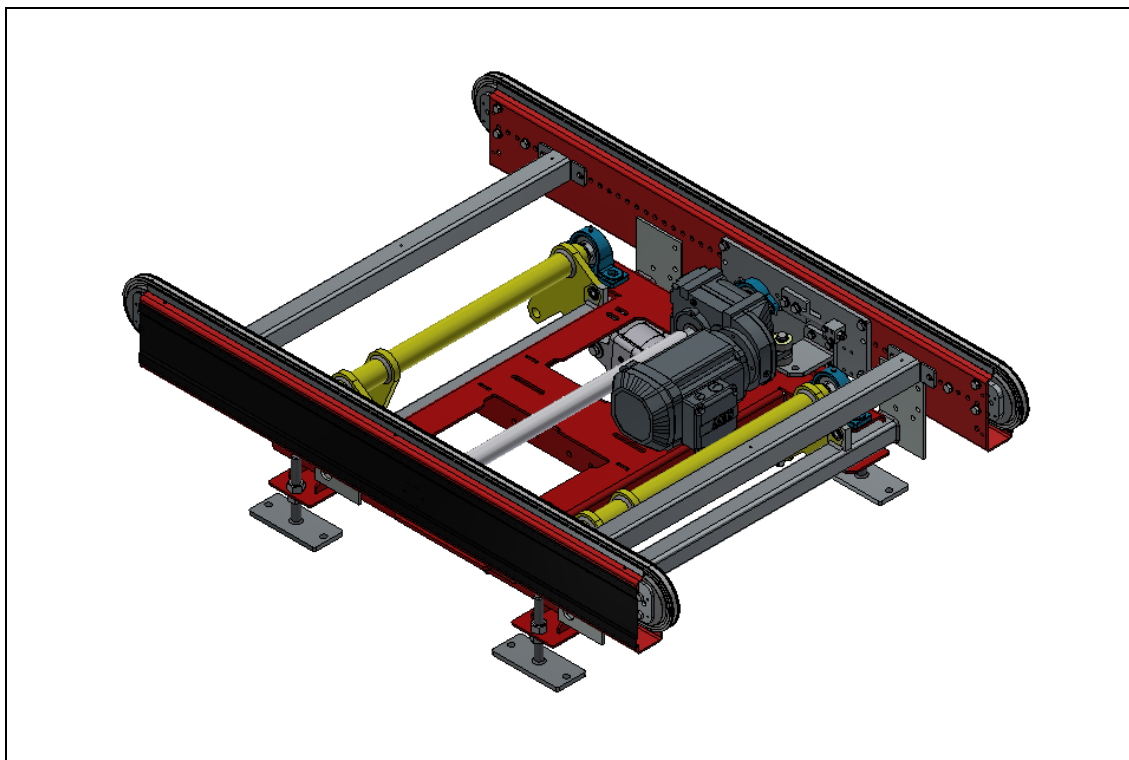

Area of application:

When entering and exiting the roller conveyor.

Technical data:

Function:	Height-adjustable function for transport at different heights.
Lifting movement:	Via 2 torque shafts, the movement of the lifting unit is transferred to a raising and lowering movement.
Width:	c/c 600 and 950.
Section lengths:	1330 and 2660 mm.
Conveyor chains:	3/4" and 3/8" roller chain with straight side washers.
Drive:	KE 500 type DM and DMS
Transport speeds:	See technical specification for each drive station.
Voltage:	230/400 V _{AC} , 50 Hz.
Protection class:	IP55.